

► **REPLACEMENT BLADE CARTRIDGE INSTALLATION**

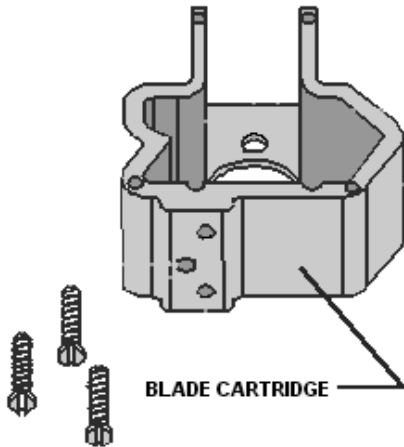

ASSEMBLE-DISASSEMBLE PROCEDURE

View Placement of **TOP PLATE**, **BOTTOM PLATE**, **CARTRIDGE SPRING**, and **BLADE CARTRIDGE**, before disassembling cutter head. Note position of **BLADE CARTRIDGE** and top plate center tube.

Cartridge blades slide into slots in center tube, it will only fit one way. Note location and position of **CARTRIDGE SPRING**, and **BRASS STANDOFFS**.

Place Cartridge into position, align with slots in Center Tube. **Important:** Do not over tighten **TOP PLATE SCREWS**.

Push cartridge back and forth into slots, to ensure proper placement before using. Be sure to check spring action, tight against end stop and cartridge.

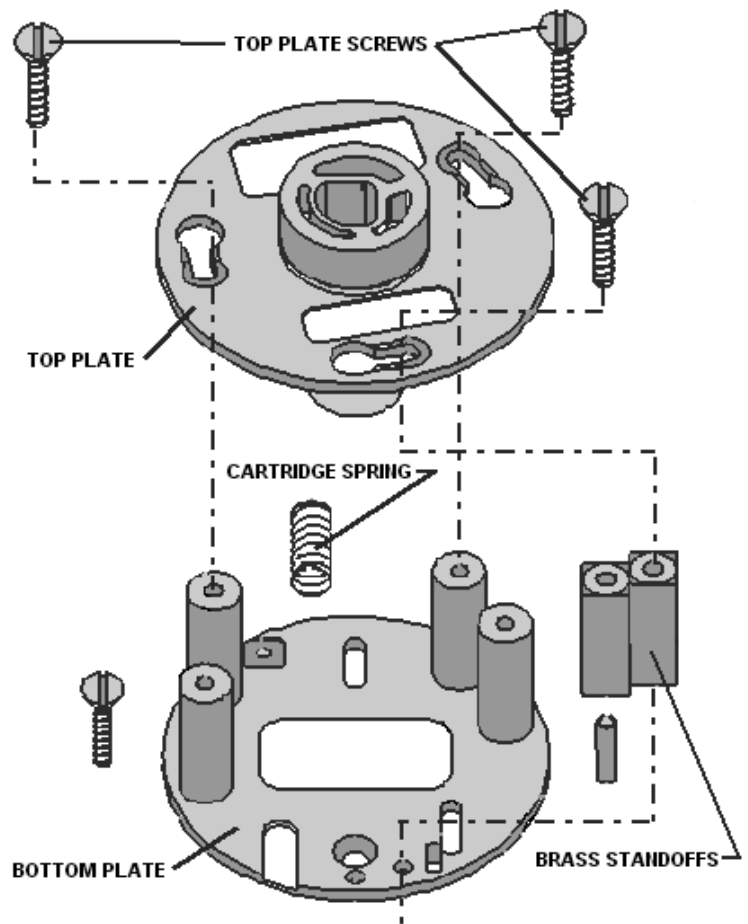

MADE IN U.S.A.



Coastel Cable Tools International Corp.

1211 South Salina Street
Syracuse, New York 13202 USA
1-315-471-5361 FAX 1-315-472-1765



1-800-451-7615

www.CoastelTools.com

